



**AL FARIDA ICE  
Company**

**2026**

**COMPANY PROFILE**

**PROJECTS &**

**EQUIPMENT PORTFOLIO**



**AL FARIDA ICE – REFRIGERATION  
& COLD ROOMS**

**PROPOSED BY :**  
Mohamed Sedik



# Table of Contents

**Page 1- Cover page**

**Page 2- Table of Contents**

**Page 3- Who We Are**

**Page 4- About Us**

**Page 5- Why Choose Us**

**Page 6- MISSION & VISION**

**Page 7- OUR SERVICES**

**Page 8- SOLUTIONS WE PROVIDE**

**Page 9- CORE VALUES**

**Page 10- Our Partners**

**Page 11- Our Clientele**

**Page 12- Our solutions**

**Page 13/14/15- Cold Rooms**

**Page 16/17/18- Display Cabinet**

**Page 19 : 41 - Cooling systems**

**Page 41 / 42 - Evaporators**

**Page 43 : 53 - spare parts**

**Page 54 - Contact Us**



# Who We Are



**Al Farida Ice is the unique choice that provides you with a comprehensive palette of engineering solutions in the world of air conditioning and refrigeration**

**We offer unique solutions that create a comprehensive range of engineering solutions in the world of heating, ventilation, and air conditioning. Our innovative designs include sandwich panel constructions, and advanced units of industrial refrigeration and rapid freezing rooms, in addition to providing all the essential materials such as the coating for evaporator units, motor winding, and control panels that offer complete control over electrical lines. We don't just stop at providing these services; we also offer maintenance services carried out by skilled professionals who are well-versed in all mechanical details alongside complete overhaul operations. Therefore, make us your technical partner that meets your expectations and creates a balance for you in the world of heating, ventilation, and air conditioning according to the highest standards**

# About Us

## About Al Farida Ice

Al Farida Ice is a leading provider of refrigeration and cooling solutions across Saudi Arabia.

We specialize in supplying, installing, and maintaining cold rooms, blast freezers, chiller systems, industrial refrigeration doors, and commercial cooling equipment.

With a skilled engineering team and a strong commitment to quality, we deliver reliable, energy-efficient systems that meet the operational needs of a wide range of industries.

## What We Do

- ✔ Industrial & commercial refrigeration
- ✔ Turn-key cold room solutions
- ✔ Engineering design & installation
- ✔ Preventive maintenance & after-sales support





# Why Choose Us

## Engineering-Driven Solutions

At **Al Farida Ice**, we don't just supply refrigeration equipment – we engineer complete cooling solutions.

Each project is carefully designed based on temperature requirements, load calculations, space limitations, and operational workflow to ensure maximum efficiency and reliability.



**High-Quality Materials & International Brands**

We work with trusted international brands and high-grade materials to ensure long service life, stable performance, and reduced maintenance costs.

## On-Time Delivery & Project Commitment

We value our clients' time.

All projects are executed according to an agreed schedule, with clear milestones and transparent communication throughout the process.

## Strong After-Sales Support

Our relationship with clients doesn't end after installation.

We offer fast technical support, preventive maintenance programs, and long-term service solutions to ensure uninterrupted operation.



**Professional Installation & Commissioning**



**Customized Solutions for Every Client**



**Energy Efficiency & Cost Optimization**



**Safety & Compliance**



# MISSION & VISION

## Our Mission

**To deliver dependable, high-performance refrigeration solutions with professional execution, quality materials, and exceptional after-sales service.**



## Our Vision

To become one of the most trusted refrigeration solution providers in the region, known for innovation, technical excellence, and customer satisfaction.

## Our Commitment

- Quality workmanship
- On-time delivery
- Long-term client partnerships
- Sustainable & energy-efficient solutions





# OUR SERVICES

## Comprehensive Refrigeration Services



We offer complete solutions for industrial and commercial refrigeration:

- Cold Room Supply & Installation
- Blast Freezer & Chiller Room Installation
- Refrigeration Door Supply (Sliding / Hinged)
- PU Sandwich Panel Supply
- Commercial Display Freezers
- Compressor, Condensing Unit & Evaporator Supply
- Troubleshooting & Repair
- Annual Maintenance Contracts
- Turn-key Refrigeration Projects

Every solution is tailored, installed, and tested for maximum efficiency.



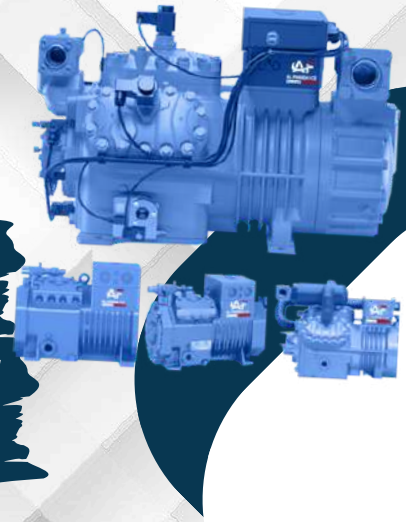

# SOLUTIONS WE PROVIDE

## Cold Room Solutions

- PU panels (various thicknesses)
- Refrigeration units (medium & low temperature)
- Sliding & hinged doors

## Freezer Systems

- Blast freezer systems
- Heavy-duty freezer doors
- High-capacity compressors & evaporators

## Commercial Refrigeration

- Display chillers / freezers
- Supermarket refrigeration
- Ice machines

## Smart Microcomputer Temperature Controller ( Mobile Control )

## Control Systems

- Danfoss / Dixell / Carel controllers
- Digital temperature monitoring
- Energy-efficient automation

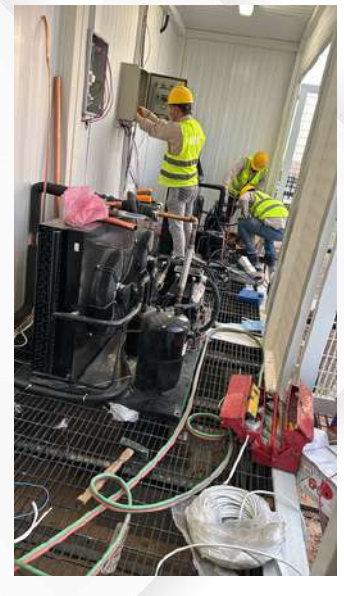

# CORE VALUES



## Core Values That Guide Us

### Quality & Reliability

We use globally recognized brands and high-end materials.

### Professional Engineering

A highly trained team delivering precise installation and commissioning.

### Customer Focus

Tailored solutions aligned with your operational requirements.

### Safety & Compliance

Full adherence to safety standards and engineering guidelines.

### After-Sales Support

Fast response, maintenance programs, and continuous technical assistance.

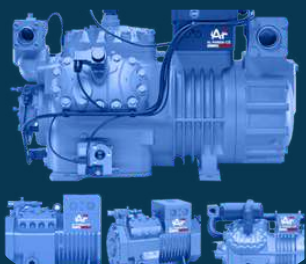

# Our Partners



Danfoss



Frigobohn



Copeland



Bitzer



Schneider Electric



Al Zamil



CadCa



Carrier



Dorrin



Supreme foods processin



Sandwich Panel SPF

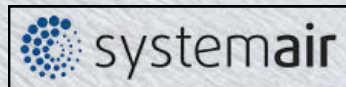

System Air



Hazm altawreed



Sandwich Panel Kipar



# Our Clientele

We are proud of our clients' confidence in A-Farida Ice, viewing them as integral partners

in our success. Since the beginning of our journey, we have forged powerful relationships with a diverse base of clientele all across the Kingdom of Saudi Arabia

**Zamil**  
Group

**Supreme**  
Foods Processing Co

ساديا  
Sadia



**Alkhaleej**  
Future Vision. Global Knowledge

أرامكو السعودية  
saudi aramco



**Transmed**



فال القابضة  
FAL HOLDINGS

**Kudu**  
كودو  
تاكلها من اول نظرة

تلج الحياة  
ALHAYAT ICE

دواجن  
الوطنية  
AL WATANIA POULTRY



## Our solutions



Cold Rooms

We design, supply, and install cold rooms tailored to different storage needs, including food, pharmaceuticals, and industrial applications, ensuring high efficiency and reliable temperature control.



Cooling Systems

We provide advanced cooling systems using high-quality components to deliver optimal performance, energy efficiency, and long-term operational reliability.



Spare Parts

We supply original and high-quality spare parts for cooling and refrigeration systems, ensuring durability, compatibility, and uninterrupted operation.



Display Cabinet

We offer a wide range of display cabinets designed to preserve product freshness while enhancing visibility and presentation in supermarkets and retail spaces.

# Cold Rooms

Proudly delivered with the highest standards of quality and efficiency



# Cold Rooms



# Cold Rooms

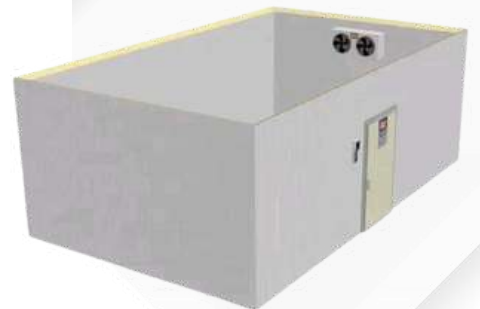
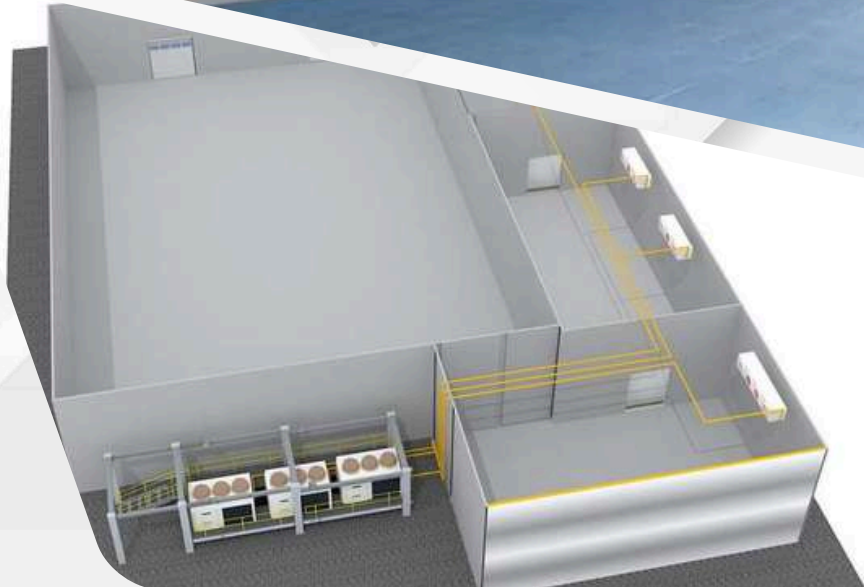
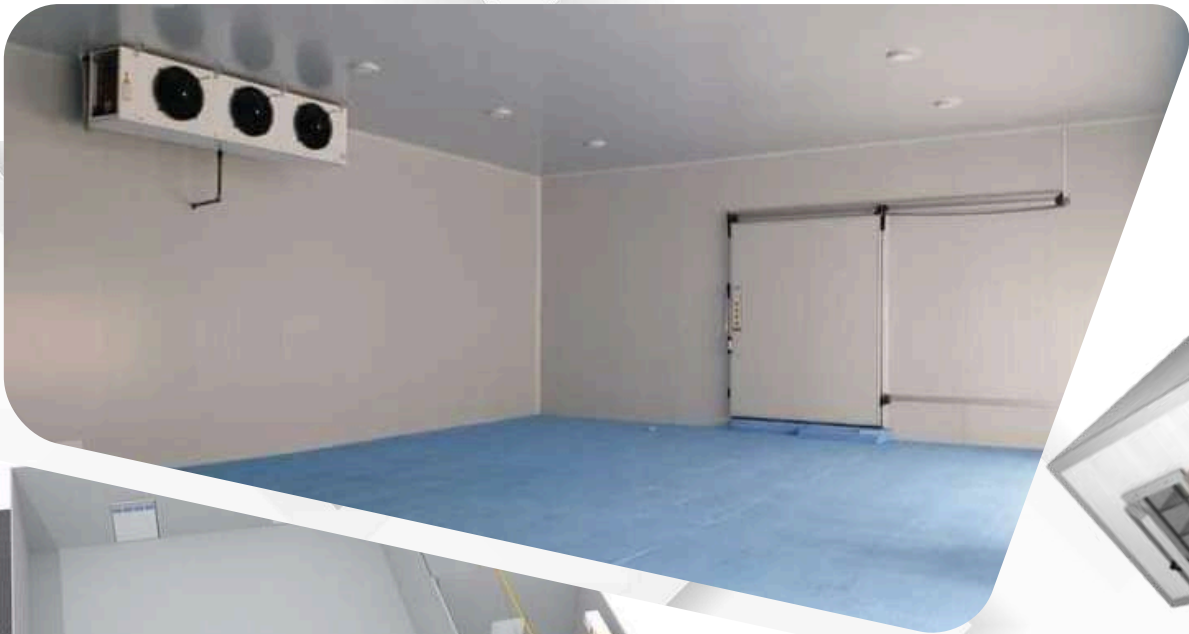

# Display Cabinet

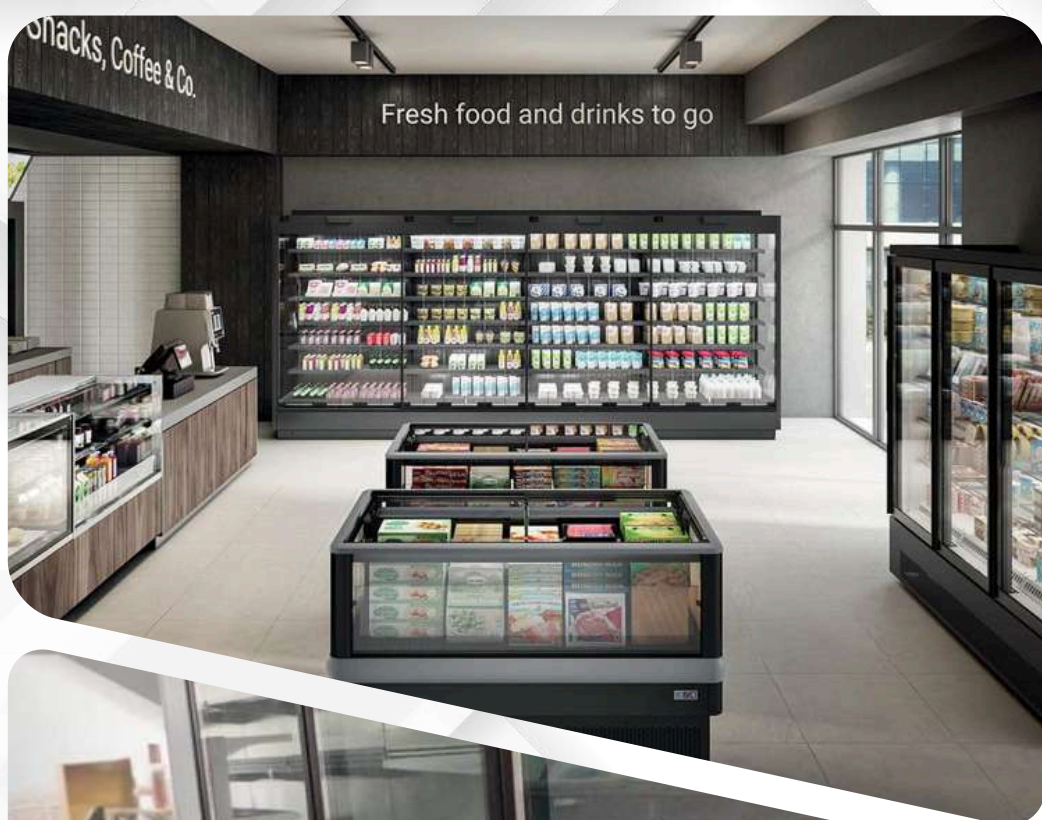



# Display Cabinet



## Cooling Units :

We have a large selection of condensing units from COPELANDO and Bitzer

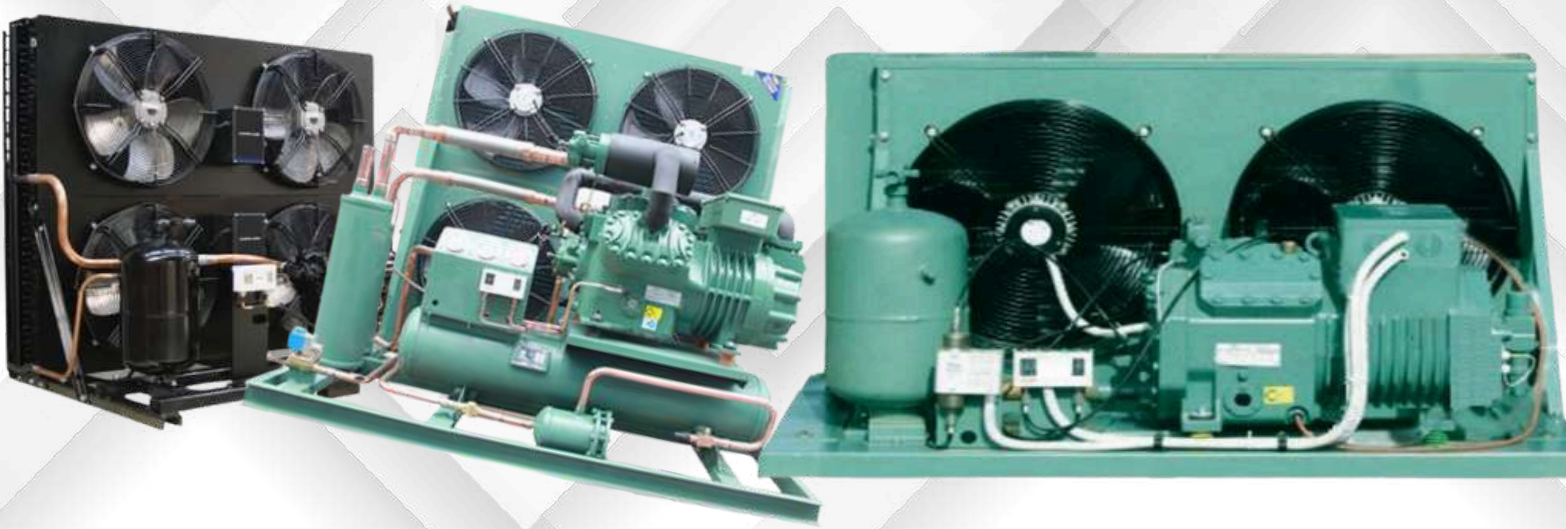

## Evaporators :

The company provides all types of FRIGA-BOHN, LU-VE and GUNTNER evaporators.



## Central units :

We offer a wide variety of central cooling units that are manufactured according to customer needs



## Compressors :

The company has a huge stock of compressors used in the field of commercial cooling systems produced by COPELAND, Bitzer and MIRACO

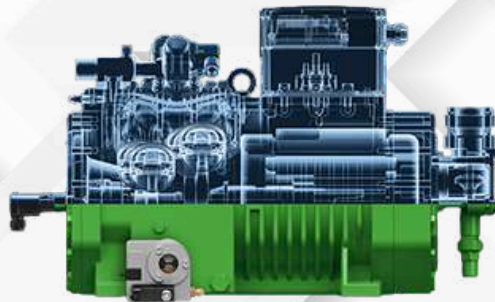

## Condensers :

The company has a huge stock of Condensers used in the field of commercial cooling systems produced by COPELAND, LU-VE and MIRACO



## Copeland Cooling Units : 1.5HP

Weight (kg)	Type	Capacity (Kw)
60	Cooling	3.26
Depth (mm)	Height (mm)	Width (mm)
680	533	735
Compressor Model	Model	
KSJ-15X	H8-KSJ-15X	

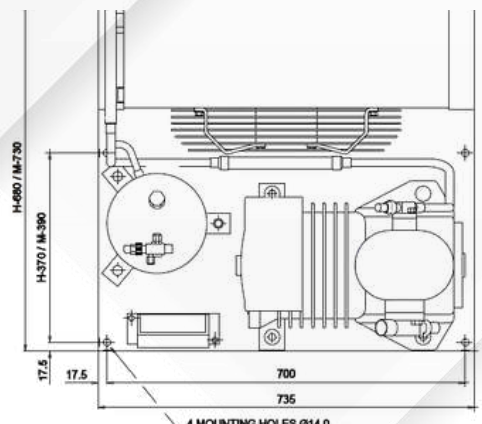

## Copeland Cooling Units : 2HP



Weight (kg)	Type	Capacity (Kw)
108	Cooling	4.06
Depth (mm)	Height (mm)	Width (mm)
680	533	735
Compressor Model	Model	
LE-20X	H8-LE-20X	

## Copeland Cooling Units : 3HP



Weight (kg)	Type	Capacity (Kw)
83	Cooling	5.11
Depth (mm)	Height (mm)	Width (mm)
730	708	735
Compressor Model	Model	
LF-30X	M8-LF-30X	

## Copeland Cooling Units : 5HP



Weight (kg)	Type	Capacity (Kw)
196	Cooling	7.66
Depth (mm)	Height (mm)	Width (mm)
820	633	1130
Compressor Model	Model	
2DC-50X	R7-2DC-50X	

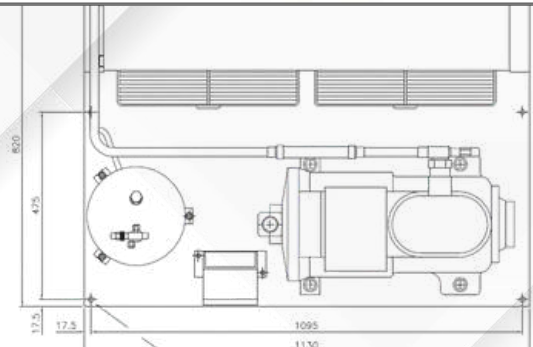

## Copeland Cooling Units : 7.5HP

Weight (kg)	Type	Capacity (Kw)
216	Cooling	11.50
Depth (mm)	Depth (mm)	Width (mm)
740	633	950
Compressor Model	Model	
2DL-75X	S9-2DL-75X	

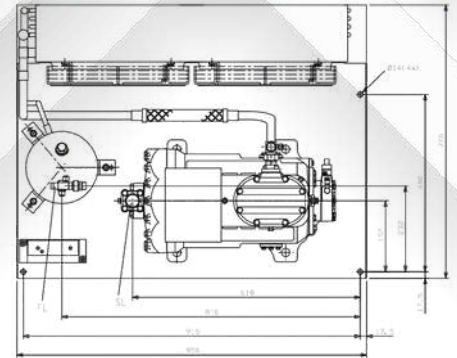

## Copeland Cooling Units : 10HP

Weight (kg)	Type	Capacity (Kw)
416	Cooling	19.30
Depth (mm)	Depth (mm)	Width (mm)
820	869	1640
Compressor Model	Model	
3DC-100X	W9-3DC-100X	

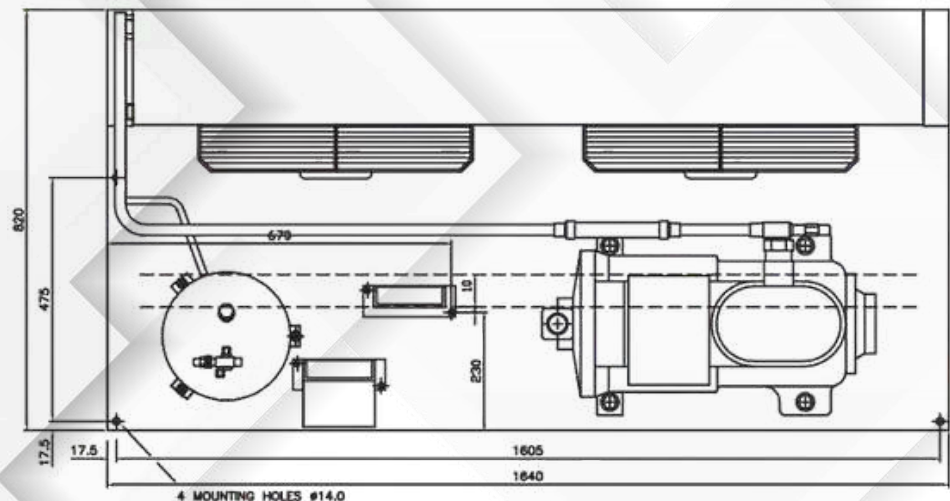

## Copeland Cooling Units : 15HP

Weight (kg)	Type	Capacity (Kw)
417	Cooling	23.70
c	Depth (mm)	Width (mm)
820	869	1640
Compressor Model	Model	
3DS-150X	W9-3DS-150X	

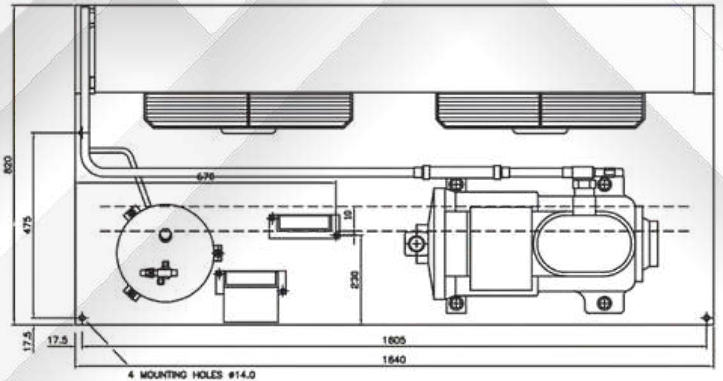

## Copeland Cooling Units : 25HP

Weight (kg)	Type	Capacity (Kw)
554	Cooling	37.60
Depth (mm)	Depth (mm)	Width (mm)
1107	1263	1600
Compressor Model	Model	
4MH-25X	Z9-4MH-25X	

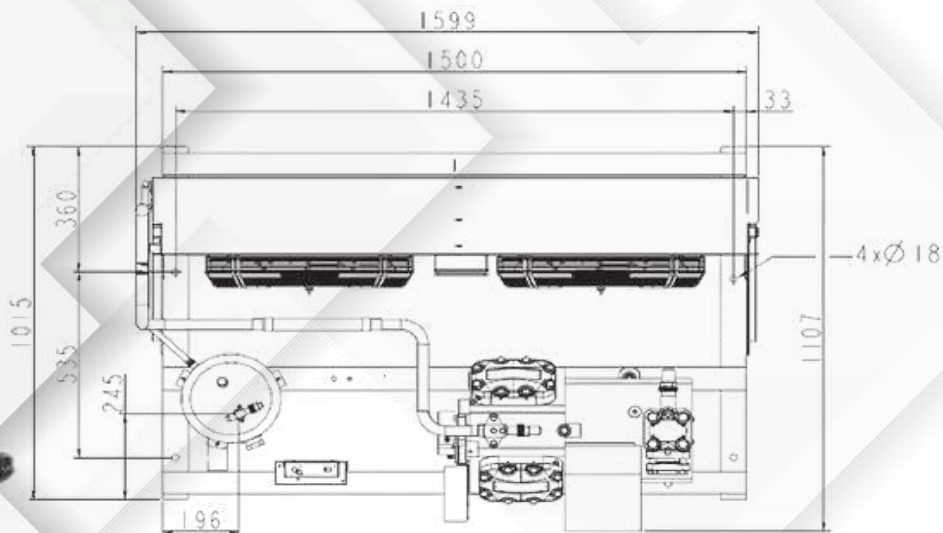

## Copeland Freeze Units : 1.5HP

Weight (kg)	Type	Capacity (Kw)
62	Freeze	1.65
Depth (mm)	Height (mm)	Width (mm)
570	446	560
Compressor Model	Model	
KL-15X	D8-KL-15X	

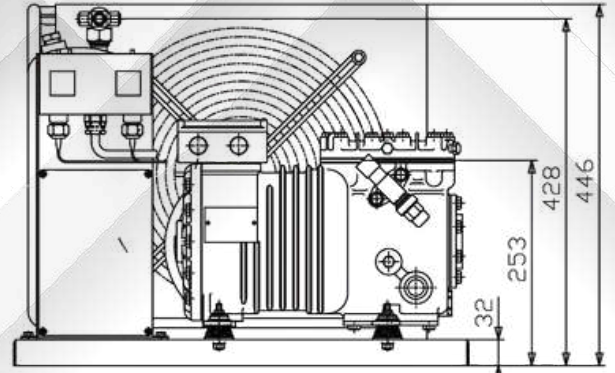

## Copeland Cooling Units : 2HP

Weight (kg)	Type	Capacity (Kw)
108	Freeze	2.24
Depth (mm)	Height (mm)	Width (mm)
680	533	735
Compressor Model	Model	
LF-20X	H8-LF-20X	



## Copeland Cooling Units : 3HP

Weight (kg)	Type	Capacity (Kw)
83	Freeze	3.38
Depth (mm)	Height (mm)	Width (mm)
680	533	735
Compressor Model	Model	
LL-30X	H8-LL-30X	



## Copeland Freeze Units : 5HP

Weight (kg)	Type	Capacity (Kw)
205	Freeze	6.09
Depth (mm)	Height (mm)	Width (mm)
820	708	1130
Compressor Model	Model	
2DB-50X	R7-2DB-50X	

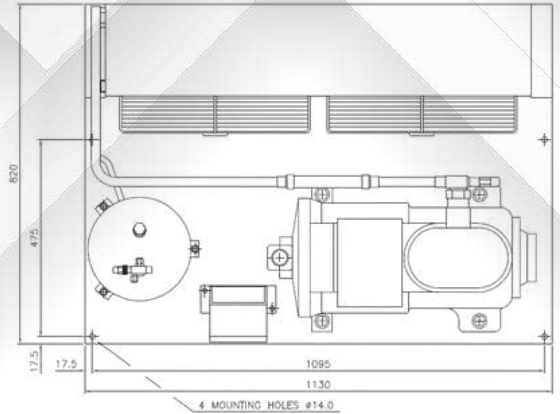

## Copeland Freeze Units : 7.5HP

Weight (kg)	Type	Capacity (Kw)
239	Freeze	8.28
Depth (mm)	Height (mm)	Width (mm)
820	708	1130
Compressor Model	Model	
3DC-75X	S9-3DC-75X	

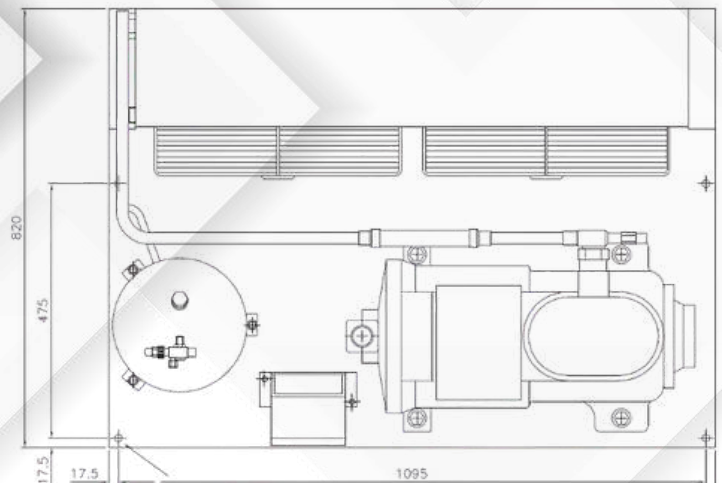

## Copeland Freeze Units : 10HP

Weight (kg)	Type	Capacity (Kw)
278	Freeze	12.35
Depth (mm)	Height (mm)	Width (mm)
820	835	1330
Compressor Model	Model	
3DS-100X	V6-3DS-100X	

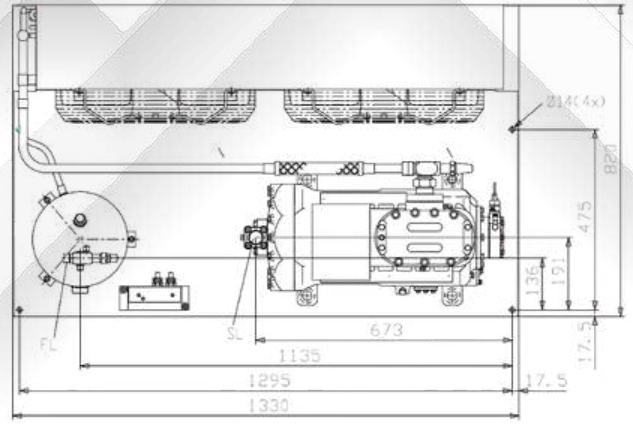

## Copeland Freeze Units : 15HP

Weight (kg)	Type	Capacity (Kw)
551	Freeze	18.45
Depth (mm)	Height (mm)	Width (mm)
1107	1263	1600
Compressor Model	Model	
4ML-15X	Z9-4ML-15X	

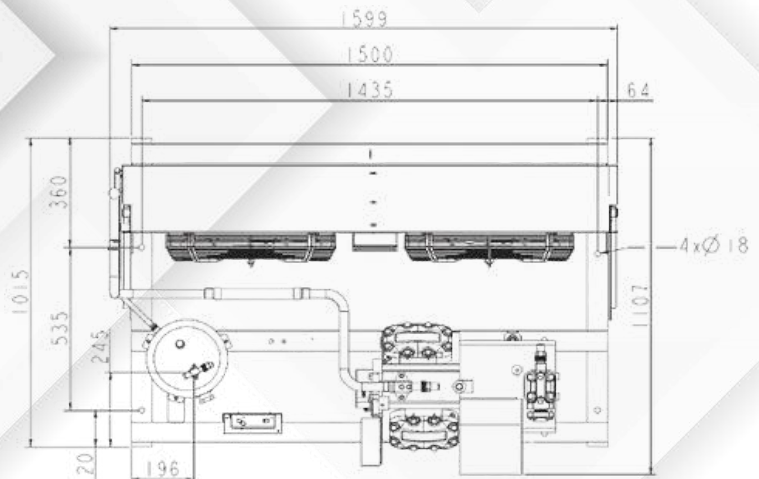

## Copeland Freeze Units : 22HP

Weight (kg)	Type	Capacity (Kw)
389	Freeze	22.20
Depth (mm)	Height (mm)	Width (mm)
1107	1263	1600
Compressor Model	Model	
4MT-22X	Z9-4MT-22X	

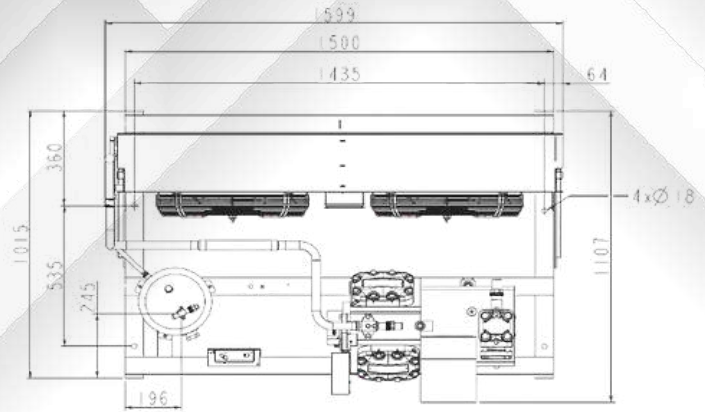

## Copeland Freeze Units : 30HP

Weight (kg)	Type	Capacity (Kw)
410	Freeze	28.10
Depth (mm)	Height (mm)	Width (mm)
1130	1263	1600
Compressor Model	Model	
6MM-30X	Z9-6MM-30X	

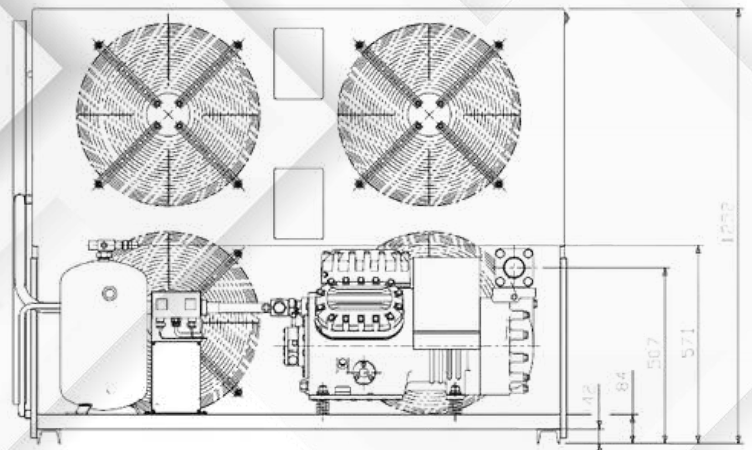

**Bitzer\_Miraco Cooling Units :**

**Cooling Unit : 1.5HP**

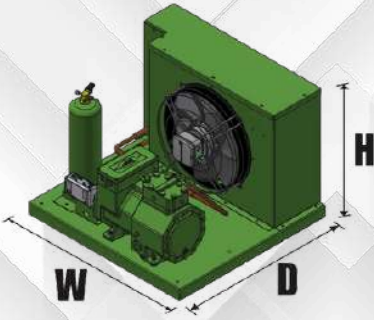

Weight (kg)	Type	Capacity (HP)
94	Cooling	1.5
Depth (mm)	Height (mm)	Width (mm)
800	615	827
Part Number	Compressor Model	Model
46308861	2HES-2Y-20D	MCRM6 - 150 - BY

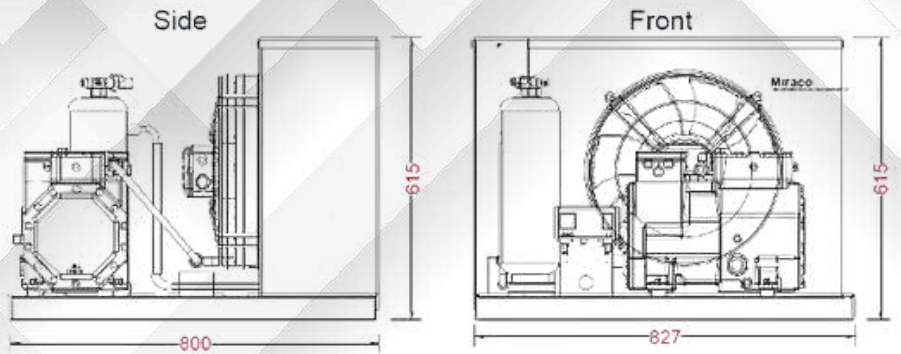

**Cooling Unit :2HP**

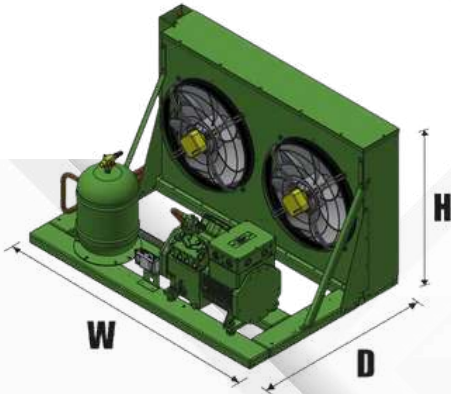

Weight (kg)	Type	Capacity (HP)
116	Cooling	2.0
Depth (mm)	Height (mm)	Width (mm)
800	615	1023
Part Number	Compressor Model	Model
46308862	2GES-2Y-20D	MCRM6 - 200 - CY

**Cooling Unit :3HP**

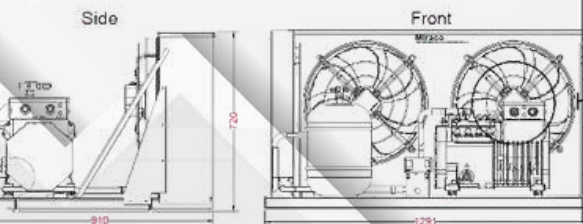

Weight (kg)	Type	Capacity (HP)
100	Cooling	3.0
Depth (mm)	Height (mm)	Width (mm)
800	615	1023
Part Number	Compressor Model	Model
46308936	2EES-3Y-20D	MCRM6 - 300 - CY

**Bitzer\_Miraco Cooling Units :**

**Cooling Unit :4HP**

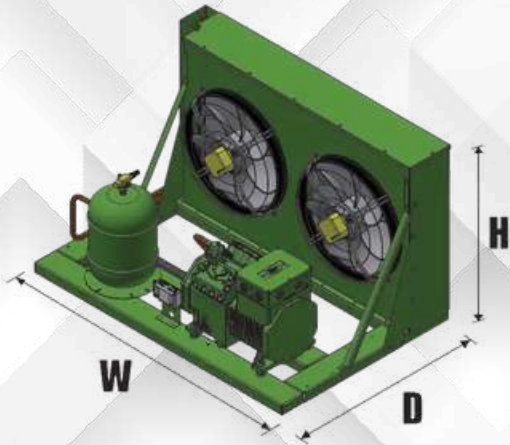

Weight (kg)	Type	Capacity (HP)
187	Cooling	4.0
Depth (mm)	Height (mm)	Width (mm)
910	720	1291
Part Number	Compressor Model	Model
46308864	2CES-4Y-20D	MCRM6 - 400 - DY

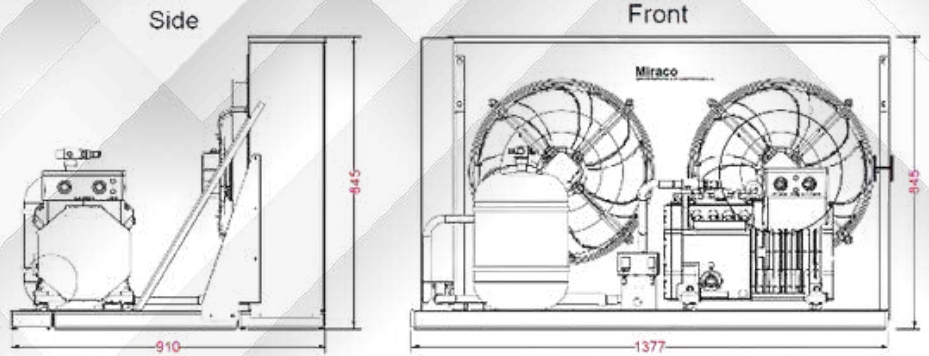

**Cooling Unit :6HP**

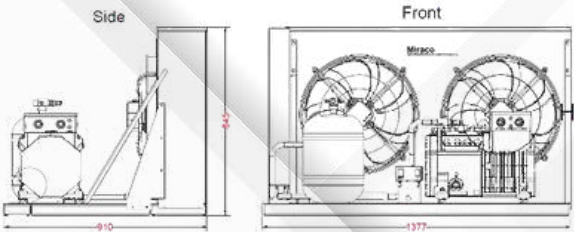

Weight (kg)	Type	Capacity (HP)
267.5	Cooling	6.0
Depth (mm)	Height (mm)	Width (mm)
910	845	1377
Part Number	Compressor Model	Model
46308865	4EES-6Y-20D	MCRM6 - 600 - EY

**Cooling Unit :7HP**

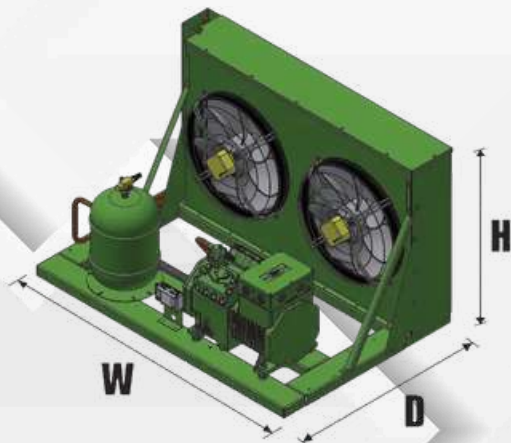

Weight (kg)	Type	Capacity (HP)
314	Cooling	7.0
Depth (mm)	Height (mm)	Width (mm)
1160	895	1665
Part Number	Compressor Model	Model
46308866	4DES-7Y-20D	MCRM6 - 700 - FY

**Bitzer\_Miraco Cooling Units :**

**Cooling Unit : 10HP**

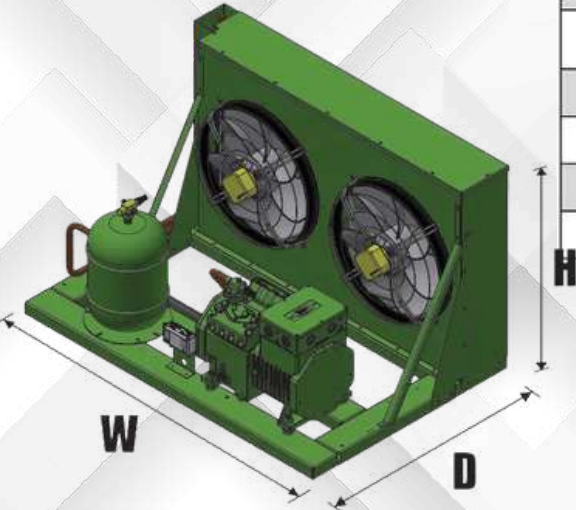

Weight (kg)	Type	Capacity (HP)
363	Cooling	10.0
Depth (mm)	Height (mm)	Width (mm)
1160	895	1665
Part Number	Compressor Model	Model
46308867	4VE-10Y-20D	MCRM6 - 1000 - FY

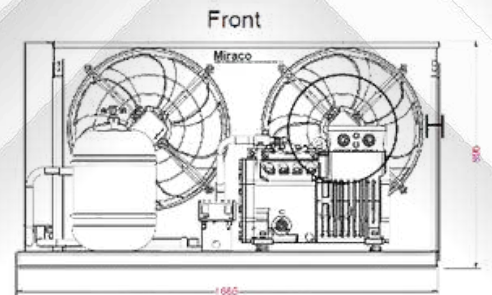
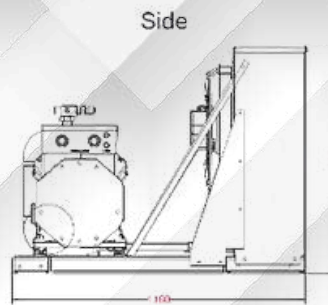

**Cooling Unit : 12HP**

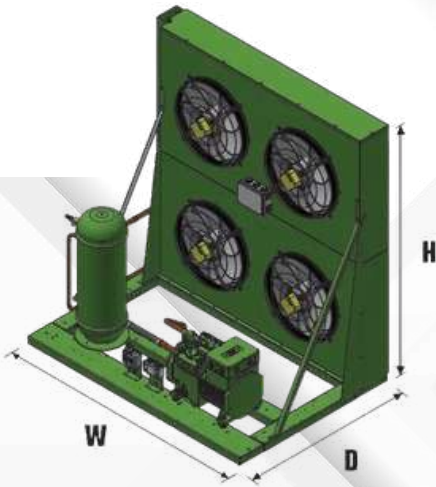

Weight (kg)	Type	Capacity (HP)
452	Cooling	12.0
Depth (mm)	Height (mm)	Width (mm)
1160	1482	1665
Part Number	Compressor Model	Model
46308868	4TE-12Y-20D	MCRM6 - 1200 - GY

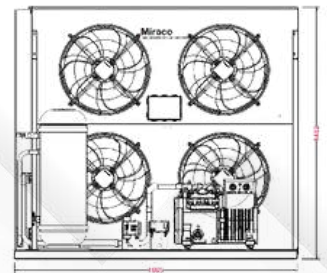
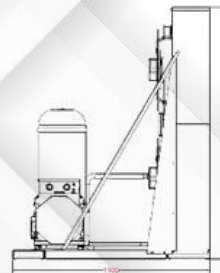

**Cooling Unit : 15HP**

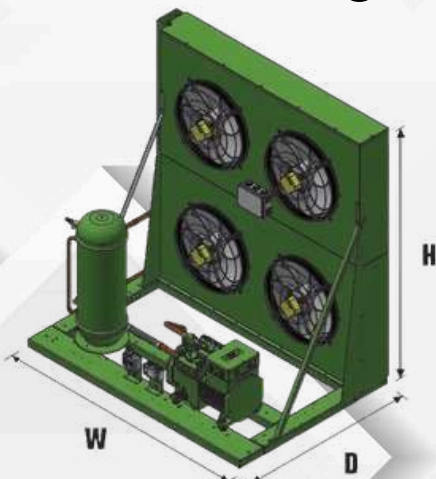

Weight (kg)	Type	Capacity (HP)
460	Cooling	15.0
Depth (mm)	Height (mm)	Width (mm)
1160	1482	1665
Part Number	Compressor Model	Model
46308869	4PE-15Y-20D	MCRM6 - 1500 - GY

## Bitzer\_Miraco Cooling Units :

### Cooling Unit : 20HP

Weight (kg)	Type	Capacity (HP)
463	Cooling	20.0
Depth (mm)	Height (mm)	Width (mm)
1160	1482	1665
Part Number	Compressor Model	Model
46308870	4NE-20Y-20D	MCRM6 - 2000 - GY

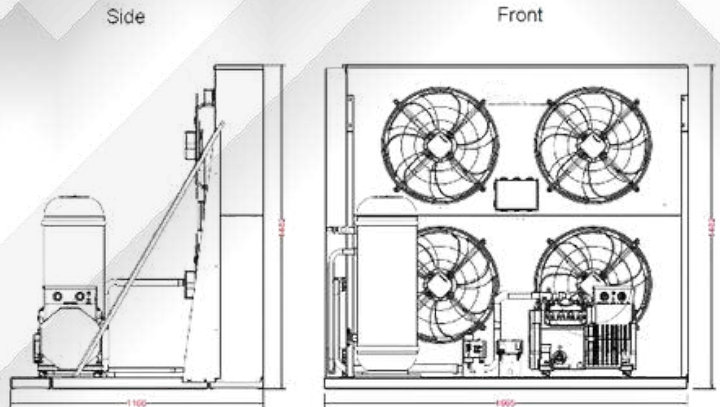
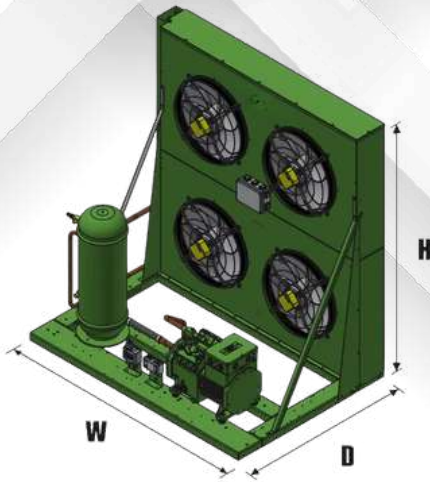

### Cooling Unit : 25HP

Weight (kg)	Type	Capacity (HP)
625	Cooling	25.0
Depth (mm)	Height (mm)	Width (mm)
1160	1735	1665
Part Number	Compressor Model	Model
46308871	4HE-25Y-20D	MCRM6 - 2500 - HY

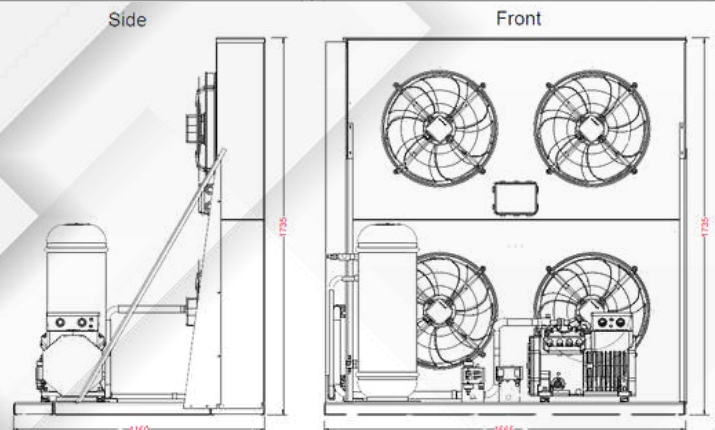
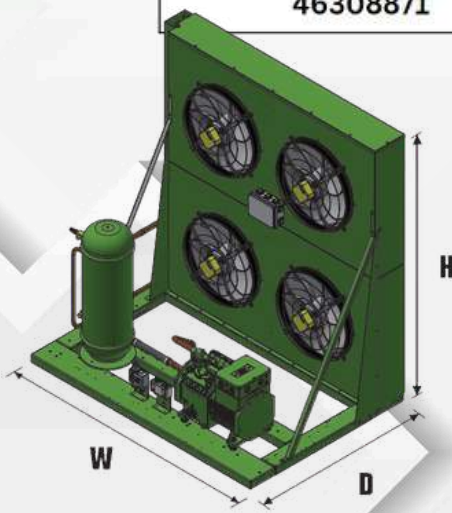

**Bitzer\_Miraco Freezing Units:**

**Freezing Unit : 1.5HP**

Weight (kg)	Type	Capacity (HP)
94	Freeze	1.5
Depth (mm)	Height (mm)	Width (mm)
800	615	827
Part Number	Compressor Model	Model
46308872	2GES-2Y	MCRL6 - 150 - BY

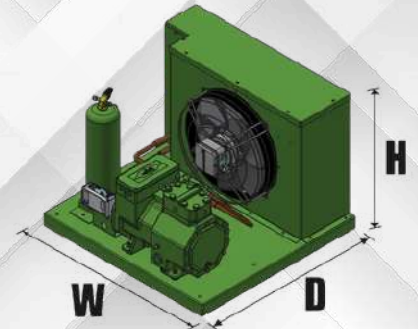

**Freezing Unit : 2HP**

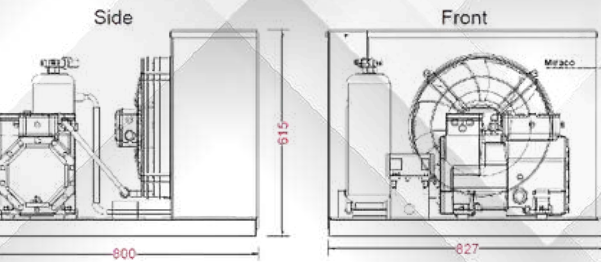

Weight (kg)	Type	Capacity (HP)
141	Freeze	2.0
Depth (mm)	Height (mm)	Width (mm)
800	615	1023
Part Number	Compressor Model	Model
46308873	2EES-2Y-20D	MCRL6 - 200 - CY

**Freezing Unit : 3HP**

Weight (kg)	Type	Capacity (HP)
143	Freeze	3.0
Depth (mm)	Height (mm)	Width (mm)
800	615	1023
Part Number	Compressor Model	Model
46308874	2CES-3Y-20D	MCRL6 - 300 - CY

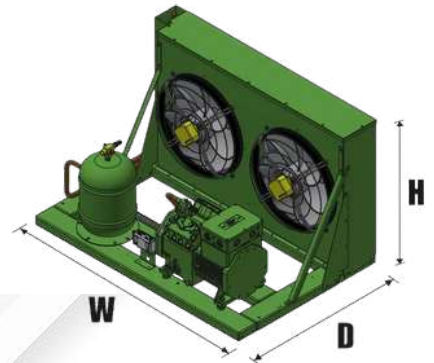

**Freezing Unit : 4HP**

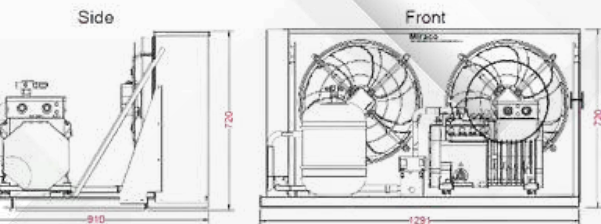

Weight (kg)	Type	Capacity (HP)
204	Freeze	4.0
Depth (mm)	Height (mm)	Width (mm)
910	720	1291
Part Number	Compressor Model	Model
46308875	4EES-4Y-20D	MCRL6 - 400 - DY

**Freezing Unit : 5HP**

Weight (kg)	Type	Capacity (HP)
205	Freeze	5.0
Depth (mm)	Height (mm)	Width (mm)
910	720	1291
Part Number	Compressor Model	Model
46308876	4DES-5Y-20D	MCRL6 - 500 - DY

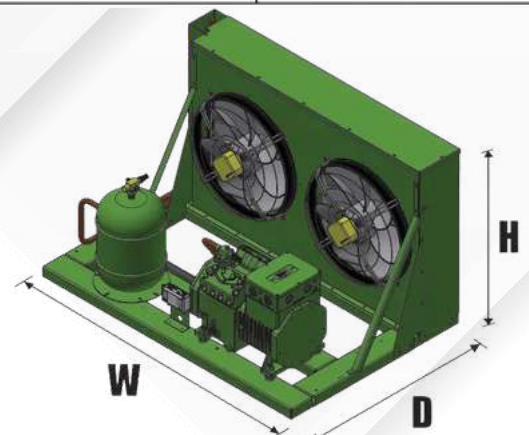

**Bitzer\_Miraco Freezing Units:**

**Freezing Unit : 7HP**

Weight (kg)	Type	Capacity (HP)
314.5	Freeze	7.0
Depth (mm)	Height (mm)	Width (mm)
910	845	1377
Part Number	Compressor Model	Model
46308877	4VE-7Y-20D	MCRL6 - 700 - EY

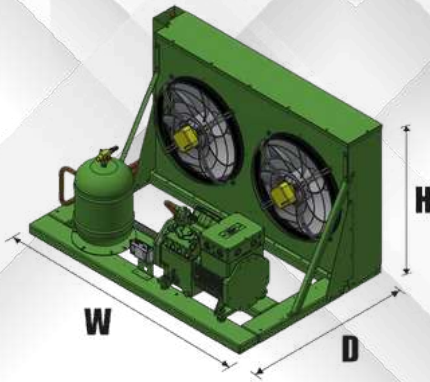
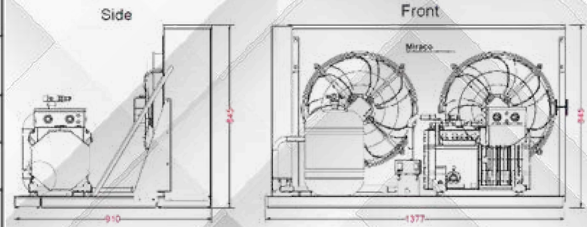

**Freezing Unit : 9HP**

Weight (kg)	Type	Capacity (HP)
316.5	Freeze	9.0
Depth (mm)	Height (mm)	Width (mm)
910	845	1377
Part Number	Compressor Model	Model
46308878	4TE-9Y-20D	MCRL6 - 900 - EY

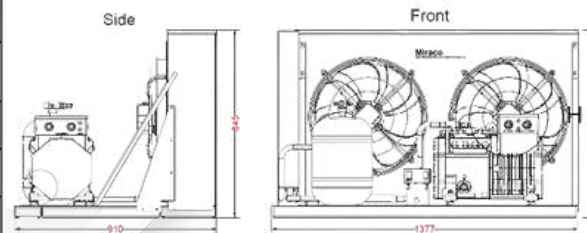

**Freezing Unit : 12HP**

Weight (kg)	Type	Capacity (HP)
319.5	Freeze	12.0
Depth (mm)	Height (mm)	Width (mm)
910	845	1377
Part Number	Compressor Model	Model
46308879	4PE-12Y-20D	MCRL6 - 1200 - EY

**Freezing Unit : 15HP**

Weight (kg)	Type	Capacity (HP)
406	Freeze	15.0
Depth (mm)	Height (mm)	Width (mm)
1160	895	1665
Part Number	Compressor Model	Model
46308880	4JE-15Y-20D	MCRL6 - 1500 - FY

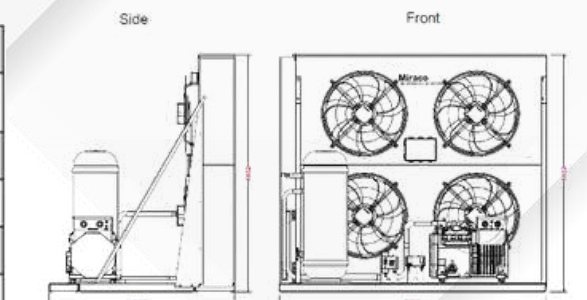
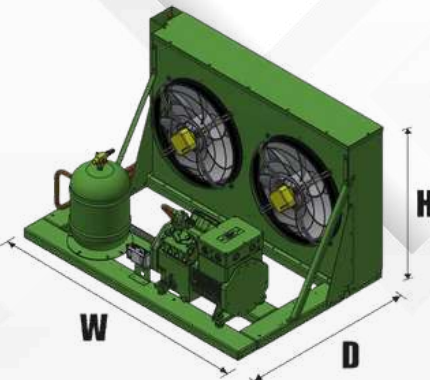

**Freezing Unit : 18HP**

Weight (kg)	Type	Capacity (HP)
495	Freeze	18.0
Depth (mm)	Height (mm)	Width (mm)
1160	1482	1665
Part Number	Compressor Model	Model
46308881	4HE-18Y-20D	MCRL6 - 1800 - GY

**Bitzer\_Miraco Freezing Units:**

**Freezing Unit : 23HP**

Weight (kg)	Type	Capacity (HP)
500	Freeze	23.0
Depth (mm)	Height (mm)	Width (mm)
1160	1482	1665
Part Number	Compressor Model	Model
46308882	4GE-23Y-20D	MCRL6 - 2300 - GY

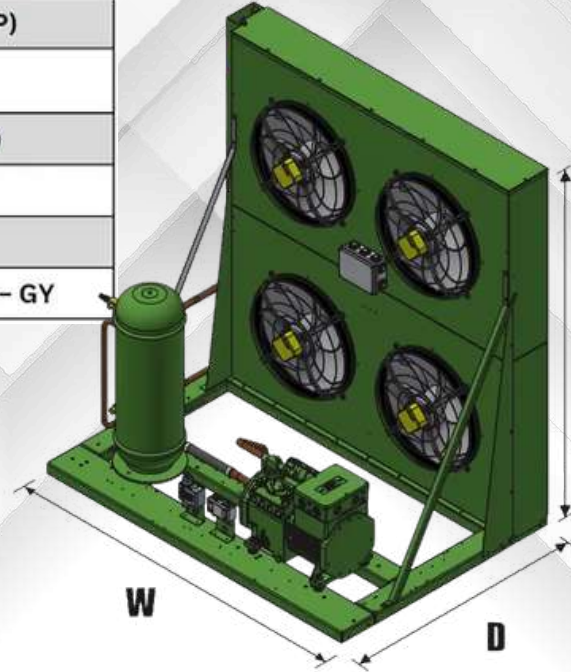
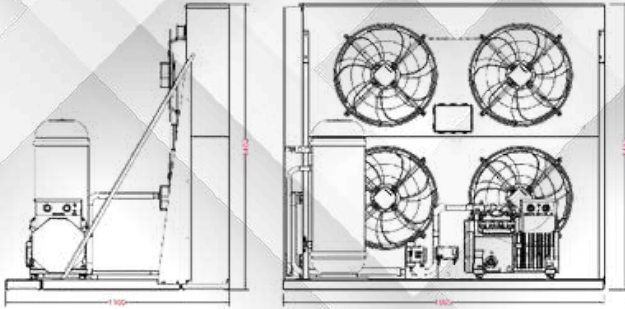

**Freezing Unit : 28HP**

Weight (kg)	Type	Capacity (HP)
627	Freeze	28.0
Depth (mm)	Height (mm)	Width (mm)
1160	1735	1665
Part Number	Compressor Model	Model
46308883	4FE-28Y-20D	MCRL6 - 2800 - HY

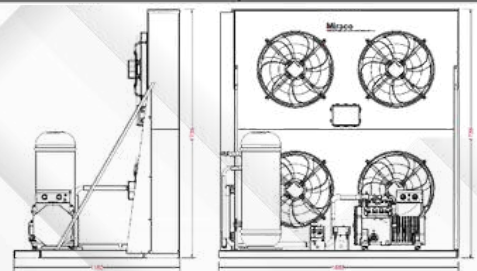
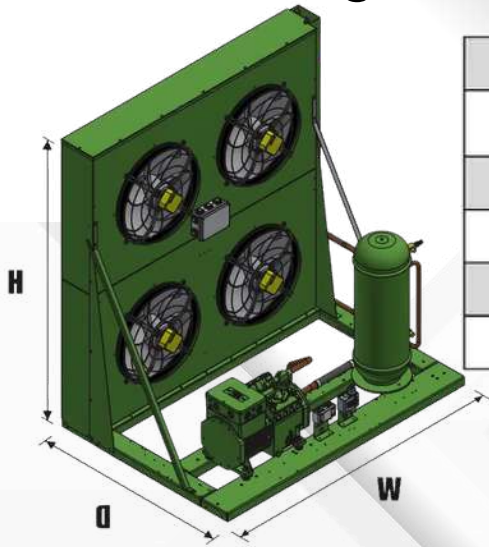

**Freezing Unit : 34HP**

Weight (kg)	Type	Capacity (HP)
650	Freeze	34.0
Depth (mm)	Height (mm)	Width (mm)
1160	1735	1665
Part Number	Compressor Model	Model
46308884	6GE-34Y-20D	MCRL6 - 3400 - HY

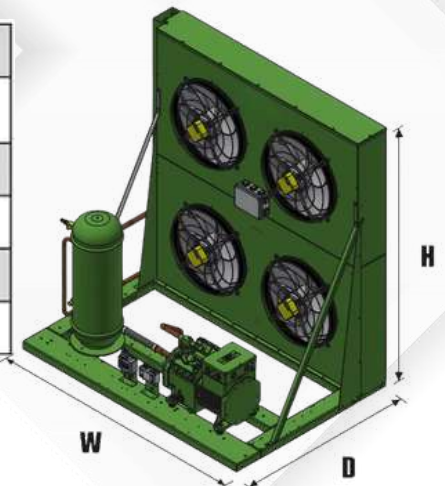

**Cooling Compressors**

**1.5 HP : Model: KSJ-15X**

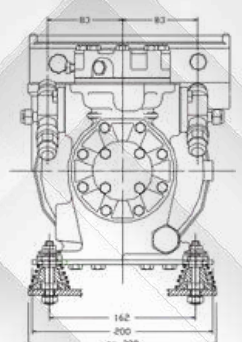
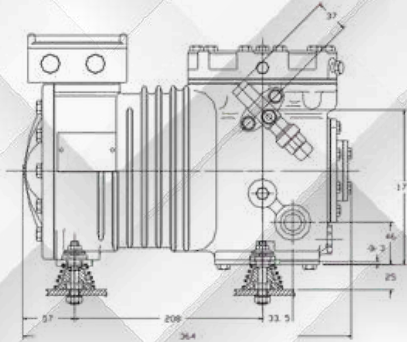
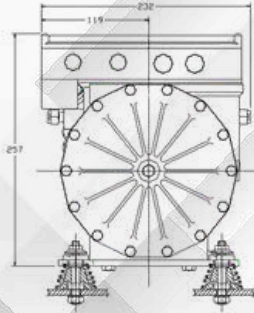

**2 HP : Model: LE-20X**

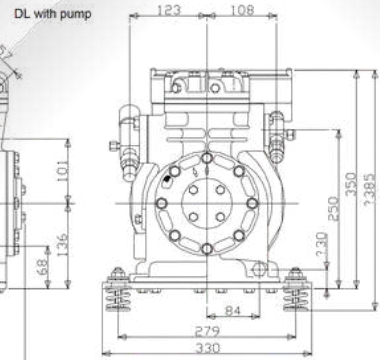
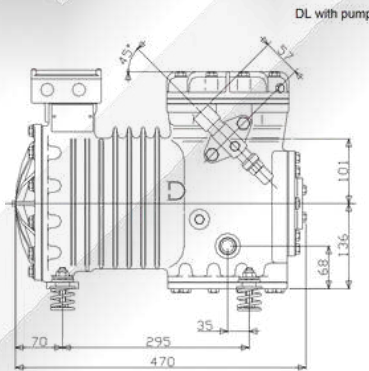

**3 HP : Model: LF-30X**

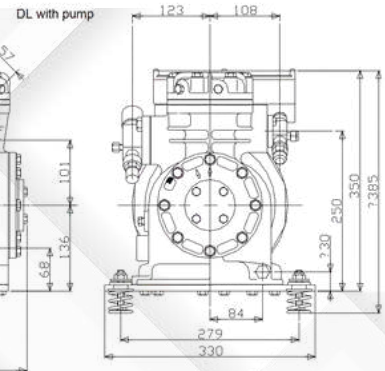
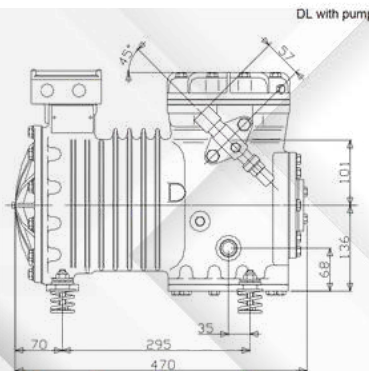

**5 HP : Model: 2DC-50X**

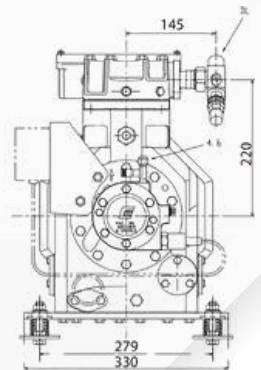
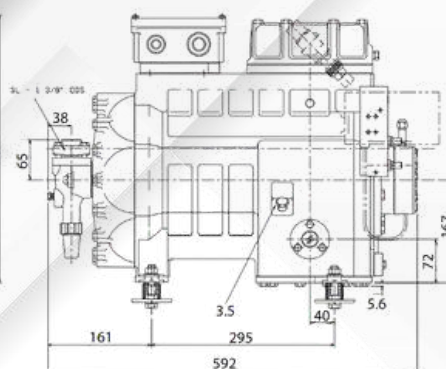
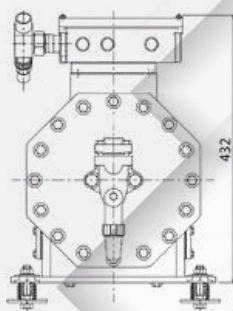

**Cooling Compressors**

**7.5HP : Model: 2DL-75X**

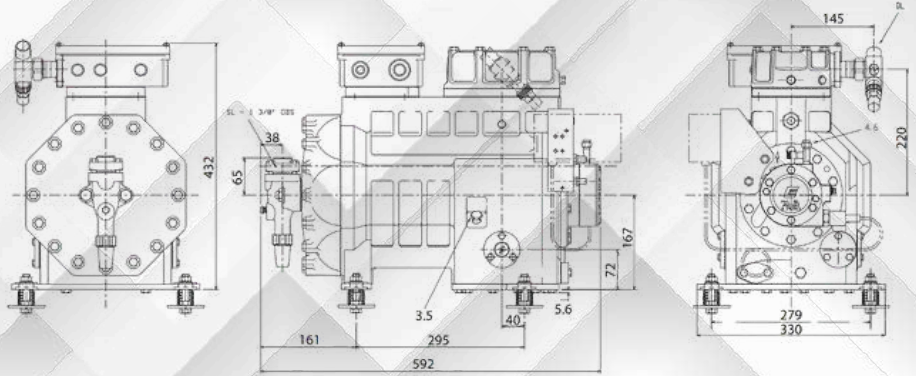

**10 HP : Model: 3DC-100X**

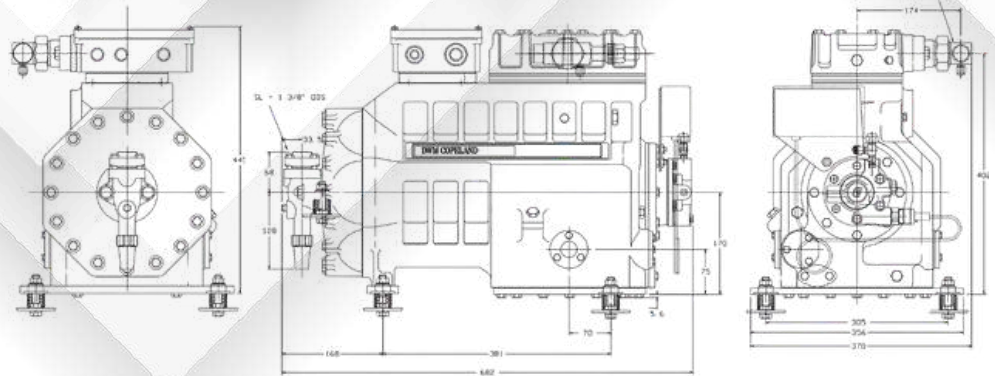

**15 HP : Model: 3DC-150X**

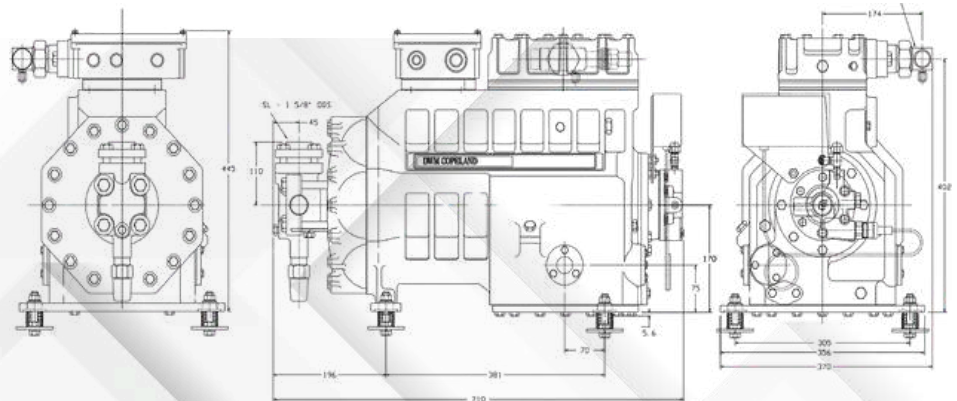

**25HP : Model: 4MH-25X**

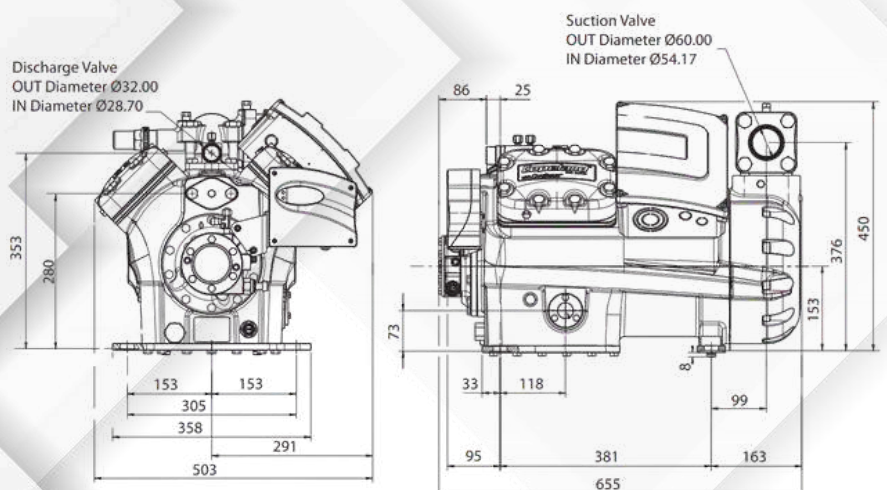

**Freezing Compressors**

**1.5HP : Model: KL-15X**

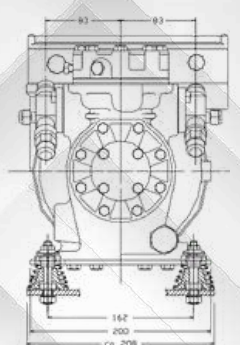
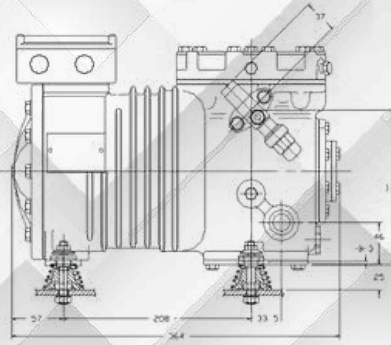
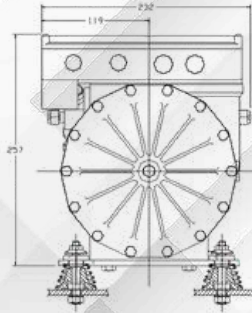

**2 HP : Model: LF-20X**

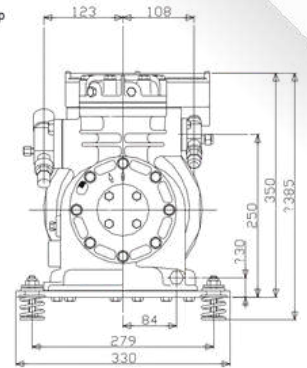
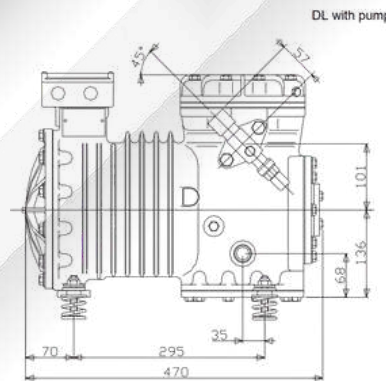

**3 HP : Model: LL-30X**

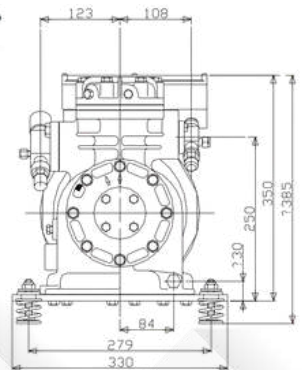
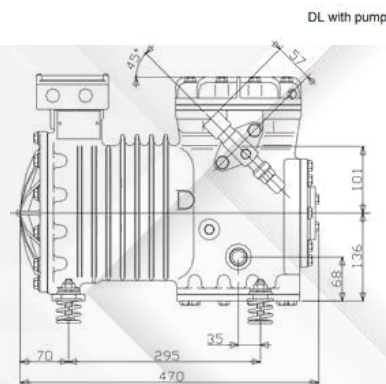

**5HP : Model: 2DB-50X**

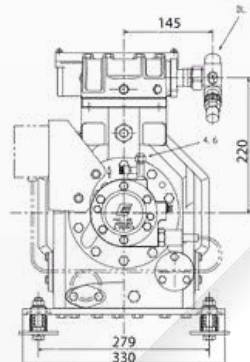
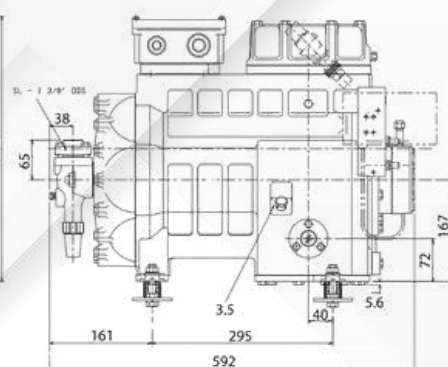
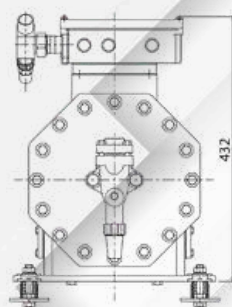

**Freezing Compressors**

**7.5HP : Model: 3DC-75X**

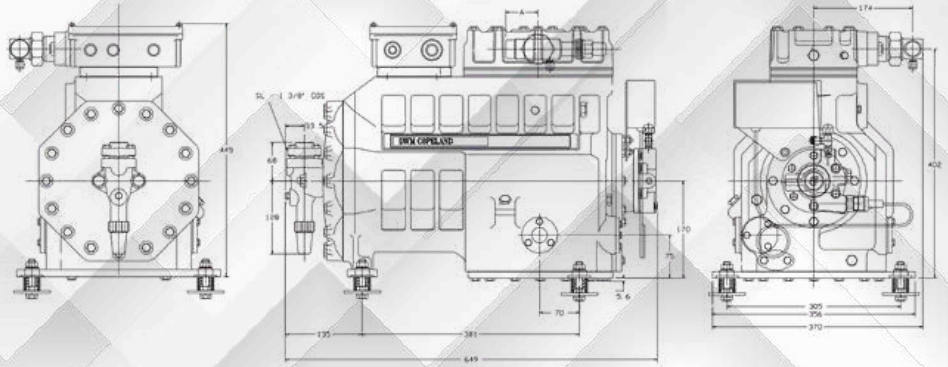

**10 HP : Model: 3DS-150X**

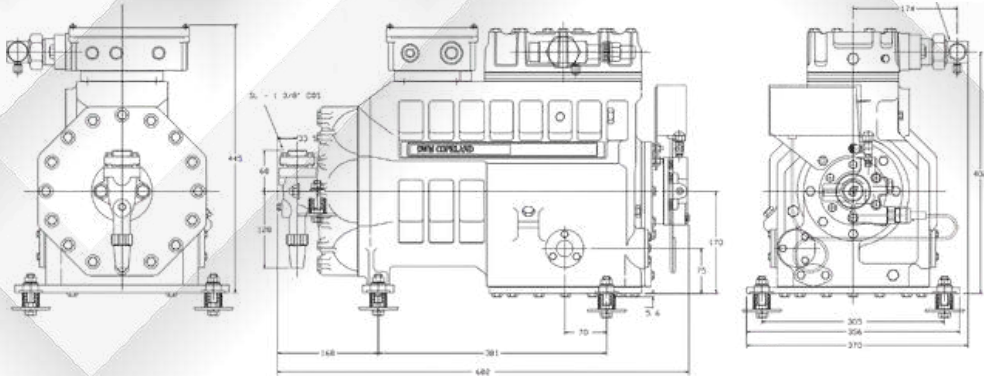

**15 HP : Model: 4ML-15X**

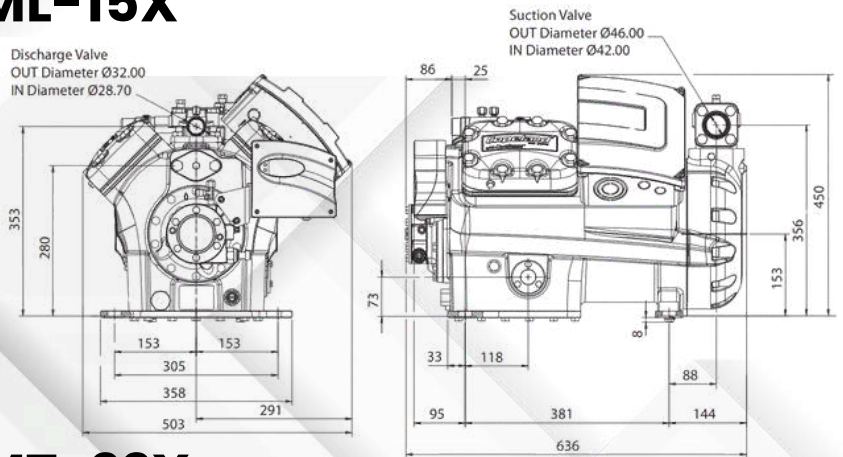

**22HP : Model: 4MT-22X**

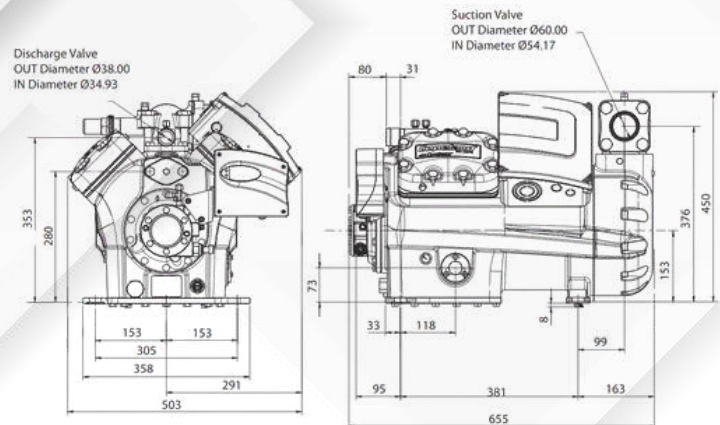

**Freezing Compressors**

**7.5HP : Model: 3DC-75X**

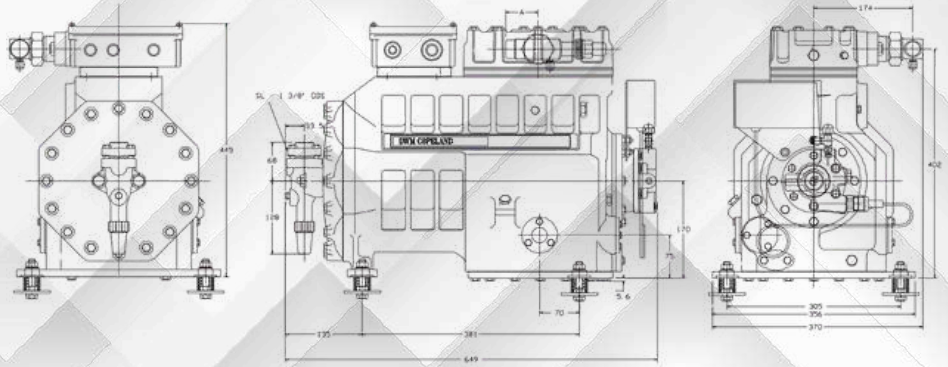

**10 HP : Model: 3DS-150X**

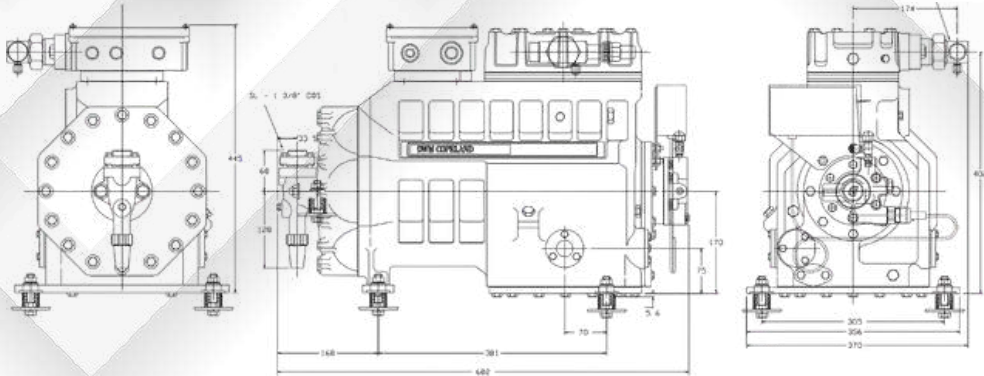

**15 HP : Model: 4ML-15X**

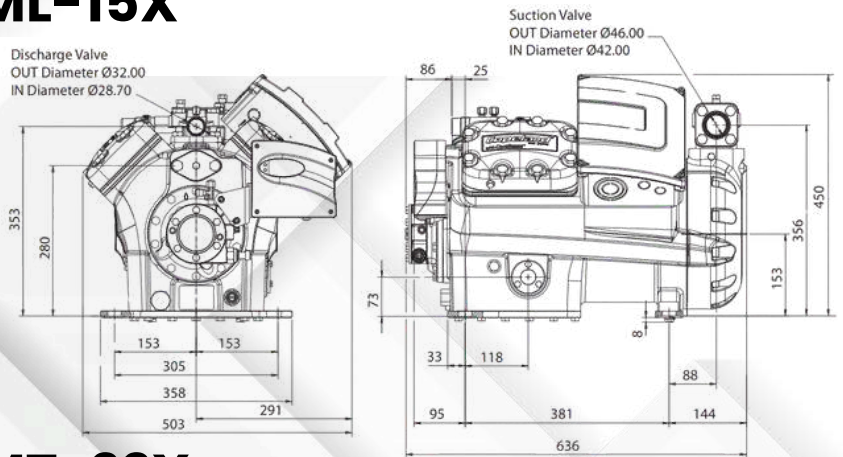

**22HP : Model: 4MT-22X**

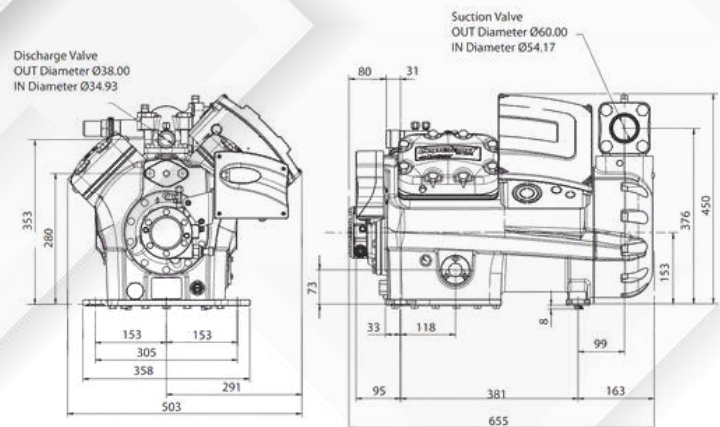

**Freezing Compressors**

**30HP : Model: 6MM-30X**



Charge Valve  
T Diameter Ø38.00  
Diameter Ø34.93

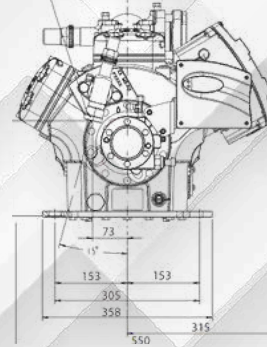

Suction Valve  
OUT Diameter Ø60.00  
IN Diameter Ø54.17

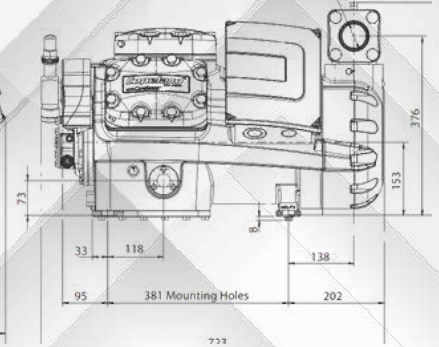

**FRIGA-BOHN**

**Evaporators**

FRIGA-BOHN is French company, leading company in the field of commercial air conditioning and refrigeration. The company is distinguished by the design and manufacture of high-quality and innovative cooling systems for stores, restaurants and hotels. FRIGA-BOHN focuses on technical innovation, providing products that meet customer needs and comply with industry standards. FRIGA-BOHN is a reliable and professional company in the field of refrigeration and air conditioning on the French market and worldwide.

**1 FAN**

**2 FAN**



**FRIGA-BOHN**

**3 FAN**

**4 FAN**



 **LU-VE**  
EXCHANGERS

**1 FAN**

**2 FAN**

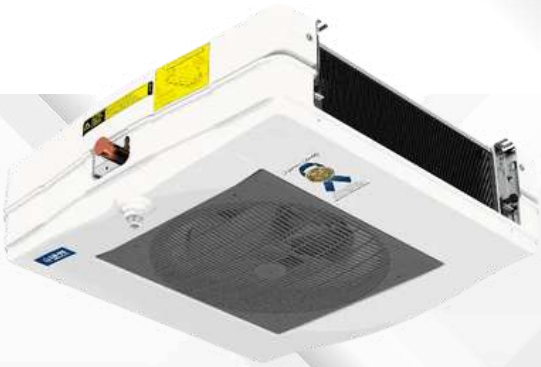

**3 FAN**

**4 FAN**



**spare parts**



Electronic thermostat



Cooling Accessories



Pipes & Copper Accessories



Gas and oil



Fans



Pressure equaliser



Door accessories



Electronic thermostat



THERMOMETERS



EWCM Rack Controller



IDplus & ICplus



Cold Room Controller  
EWRC 500 NT 3



Cold Room Controller  
EWRC 5030 NT 3



Cold Room Controller  
IDPanel



Pressure Transducer  
EWPA



Pack Controller AK-  
PC 551



Digital Thermostat



Cold storage Room  
Controller AK-RC111



Cooling Accessories



Pressure Control Series  
PS01/50/15



Thermostatic  
Expansion Valve RFGC



Thermostatic  
Expansion Valve RFKH



Solenoid Valve MDF



Electronic Expansion  
Valve DPF



Ball Valve CBV



Filter Driers with Replaceable  
core HTG



Ball Valve SBV



Pressure Sensor  
Series YCQB & YCQC



Unidirectional Filter  
Driers DTG



Check Valve Piston  
Type YCVS



Sight Glass SYJ



SD2 Variable Speed  
Drives



SEC Heavy Duty Electronic  
Expansion Valve Controller



Braze Plate Heat  
Exchangers



Micro Channel Heat  
Exchangers



Cooling Accessories



Suction Filter Shell



Liquid Filter Shell



Filter Drier



Solenoid-Valves



Thermostatic Expansion Valves



Pressure Switch PS1



Sight Glass HMI



Ball Valve



Suction Filter Core 100



Liquid Filter Core 48



Cooling Accessories



Ball Valve



Filter drier



Solenoid valve



Expansion Valve



Filter Drier2



Oil control systems



Vibration absorbers



Sight Glass



**Cooling Accessories**



Solenoid Valves

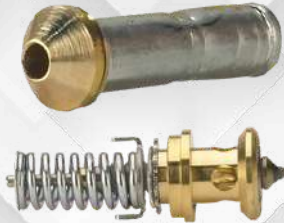

Orifices



Thermostatic Expansion Valve TE 5



Thermostatic Expansion Valve TE 2



Liquid Filter Core 48



Suction Filter Shell



Liquid Filter Shell



Filter Drier



Pressure Switch KPI5



Pressure Switch KPI



Sight Glass



Ball Valve



Temperature sensor, EKS



Heat Exchanger Tube-In-Tube



Evaporator Pressure Regulator KVP 15



Differential pressure switch, MP54



Pressure transmitter, AKS



Temperature sensor, AKS



Fan speed controller, XGE-6C



Cooling Accessories



Oil Reservoirs



Oil Separators



Suction Line Accumulators



Liquid Receivers



Filter driers Shell

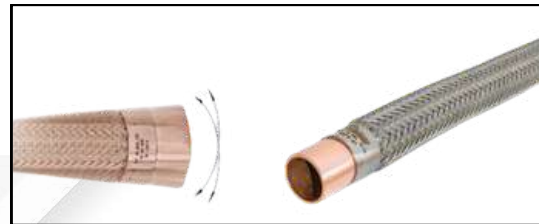

Vibration eliminators VAFS



Differential pressure and check valves



Oil Filter



Electronic oil level regulators ERM



Mechanical Oil Level Regulators (OR)



Cooling Accessories



VIBRATION ABSORBER



SUCTION LINE ACCUMULATOR



Oil Level Regulators



INT69 TM2



SUCTION LINE ACCUMULATOR



SUCTION LINE ACCUMULATOR WITH HEAT EXCHANGER



Delta PII 3



Delta PII 2



OIL STRAINER



CONVENTIONAL OIL SEPARATOR



Temperature Sensors Pt100-Pt1000



INT69 B1



Pipes & Copper  
Accessories

**MUELLER  
STREAMLINE CO.**

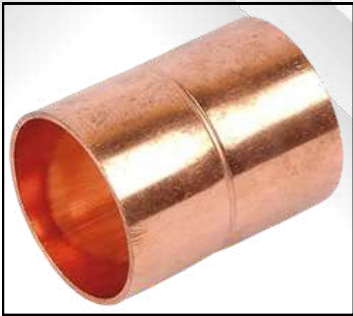

COUPLING



90' ELBOW



45' ELBOW



P TRAP



REDUCER



TEE

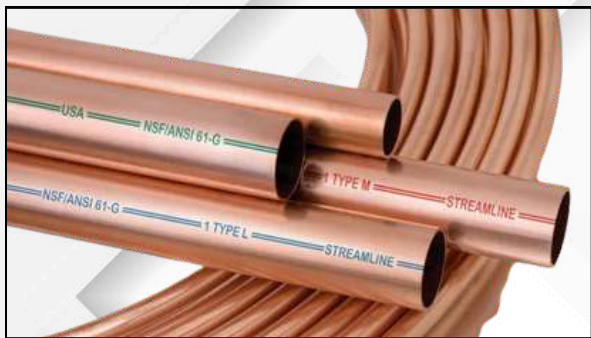

PIPE



Fans



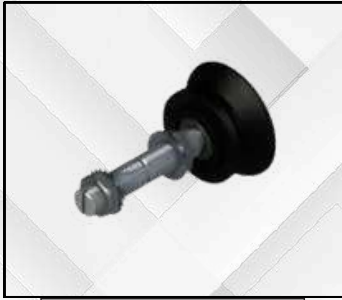

pa wheel w/bearing



Door accessories



REAR GUIDE PLUG



REAR GUIDE BRACKET

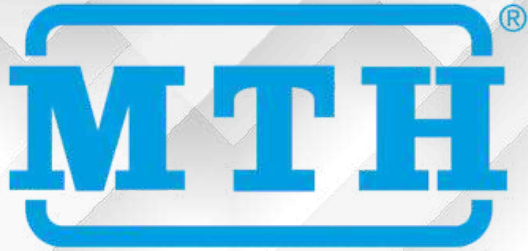

Base and wheel zipper door



PLASTIC STRIKER X EXTERNAL LEVER HANDLE



RH/IH REAR REGISTER



TERMINAL CAP



WHOLE CLOSING BLOCK



WHOLE CLOSING BLOCK

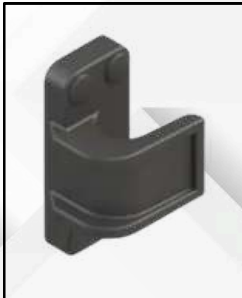

LOWER CLOSING HOOK



hook pickup



EXTERNAL HANDLE TH=68



EXTERNAL FIXED HANDLE



perimetral Gasket



SLIDING door key - lock

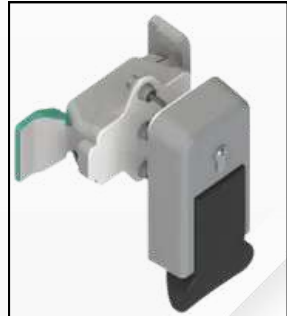

Italian cold room door handle

**Let's Work Together**



**Contact Us**



+966 598366214



Dammam - AL Ahsa - Al Qassim  
- Riyadh - Jeddah

